

SIDE ELEVATION

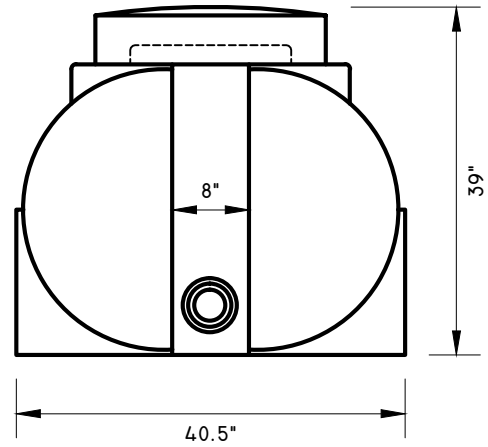

END ELEVATION

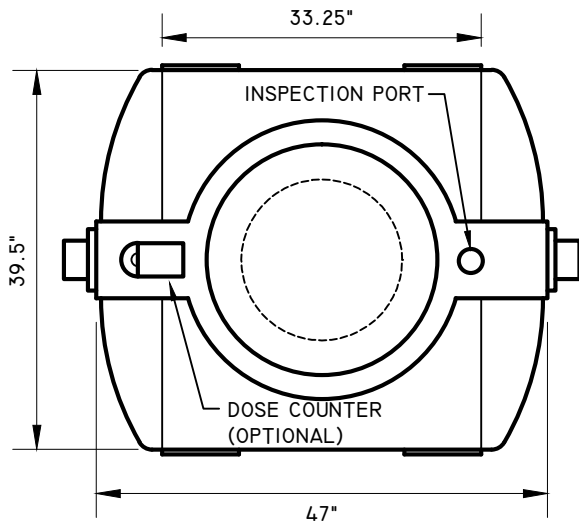

TOP VIEW

SERVICE

FOR GRAVITY OR PRESSURE SEPTIC DISTRIBUTION FIELDS
 - SUBJECT TO HEAD AVAILABILITY.
 EXPOSES ENTIRE FIELD TO EFFLUENT.
 - REJUVENATE EXISTING
 INCREASES EFFICIENCY AND LIFE OF FIELD.
 LESS COST AND MORE RELIABLE THAN SIPHON SYSTEMS.
 DOSAGES CAN BE FACTORY PRE-SET.
 NO STANDBY VOLUME REQUIRED FOR DOSING TANK.

OPERATION

1. FLOUT® FLOATS UP WITH RISING EFFLUENT IN TANK.
2. AT MAXIMUM RISE, EFFLUENT SPILLS INTO FLOUT®. FLOUT® LOSES BUOYANCY AND SINKS BACK.
3. EFFLUENT DISCHARGES THROUGH THE FLOUT® UNTIL LEVEL REACHES TOP OF FLOUT®. EFFLUENT IN FLOUT® AND DISCHARGE PIPE THEN DRAINS OUT.
4. FLOUT® RE-FLOATS TO RESTART THE CYCLE.

CALIBRATED DOSES UP TO 90 US GAL.
 AVERAGE DISCHARGE RATE 60-70 USGPM.

ASSEMBLED PACKAGE INCLUDES: (4 TANK SIZES)

POLY HOLDING TANK; 3" DIA. X 20" LONG FLOUT, FALLBACK STOP AND VENT/OVERFLOW; 4" INLET SEWER PIPE, RUBBER BUSHING AND INTERNAL FLOW DEFLECTOR; 3" DIA. DISCHARGE BULKHEAD FITTING AND 3' SCHED. 40 MALE ADAPTER; 24" DIA. POLYLOK ADAPTER RING, 6" HIGH RISER AND COVER.

NOTE: ALL DIMENSIONS AND VOLUMES ARE NOMINAL



www.premierplastics.com 1-800-661-4473

FLOUT® DOSING TANK

155 US. GALLON - FLTUI55

POLYETHYLENE

DATE: DEC 2012

SCALE: -

DRAWN: SGM

DWG. No. FLTUI55

REV. 1