

**NEW!**

# BIG BENNY

## DRAINAGE

## SUMP

**SAVE TIME AND MONEY**

- ★ Fast installation - replaces concrete
- ★ Tough, lightweight polyethylene
- ★ No heavy equipment needed
- ★ No gluing or grouting
- ★ Will not crack or corrode
- ★ One piece, leak-proof construction
- ★ Surface access for easy service

### IDEAL FOR

- ★ Roof and perimeter drains
- ★ Driveways and parking lots
- ★ General landscaping



**Look for the PREMIER label of quality.**

### SPECIFICATIONS

- ! Standard weight 65 lbs. / Max. cover 12"
- ! Extra heavy weight 90 lbs. / Max cover 36"
- ! Total vol.: 70 imp. gals.
- ! Slip joint pipe connections
- ! Pipe entry can angle up to 15° off centre
- ! Environmentally safe
- ! Do not place in direct path of vehicles
- ! **100 year warranty**

### \*\* SAMPLE LAYOUT

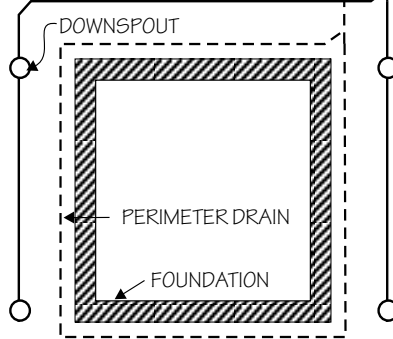

\*\* Subject to local regulations

### SECTION OF SUMP

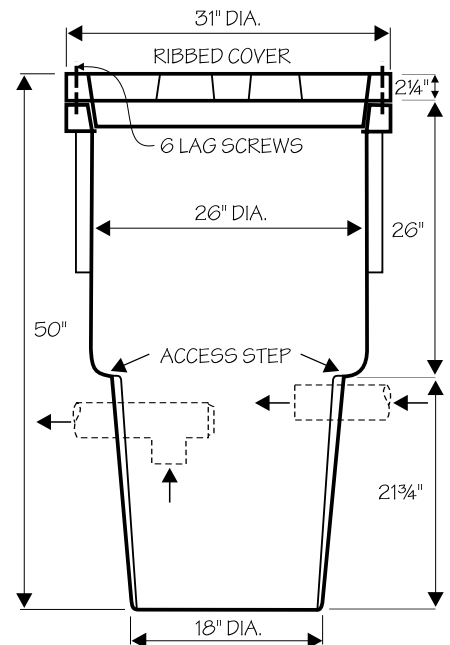

### SELECTION GUIDE

APPLICATION	MODEL #	FITTINGS
Drainage Sump	DS 70	2 - 4" inlets - invert 33" from top 1 - 4" outlet - invert 35" from top
Pump Out	PO 70	1 - 4" inlet - invert 10" from top
Catch Basin/Dry Well	CB 70	Connections and perforations as required
Cistern Tank	CIS 70	Fittings as required by customer

• Accessories - Riser 21/31



**PREMIER PLASTICS INC.**

8328 River Way, Delta, BC, Canada V4G 1C4  
 Bus: (604) 952-6686 Fax: (604) 952-6696  
 Toll Free: 1-800-661-4473  
 E-mail: premier@ultranet.ca  
 www.premierplastics.com

Represented by: